

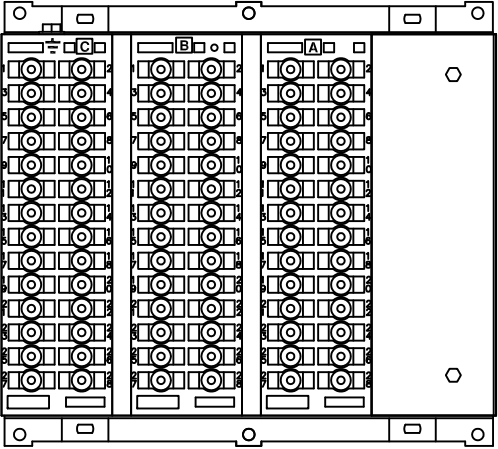

IF IN DOUBT ASK
DO NOT SCALE

| ABBREVIATIONS | |
|---------------|--|
| I- | CURRENT INPUTS |
| BI- | BINARY INPUTS |
| BO- | BINARY OUTPUTS |
| CO- | CHANGE OVER BINARY OUTPUT CONTACTS |
| NO- | NORMALLY OPEN BINARY OUTPUT CONTACTS |
| NC- | NORMALLY CLOSED BINARY OUTPUT CONTACTS |

| COMMUNICATIONS IDENTIFICATION | |
|-------------------------------|--|
| COM1 | RS485 (ON BLOCK 'B' TERMINALS 14,16,18 & 20) |
| COM2 | USB TYPE'B' PORT (ON RELAY FRONT LABEL) |
| | |
| | |



RELAY VIEWED FROM REAR

NOTES

- TERMINALS RECOMMENDED ARE PRE-INSULATED & MUST BE CRIMPED USING APPROVED TOOLING. AMP PIDG OR PLASTI GRIP FUNNEL ENTRY (RING TONGUE) FOR M4 FIXING STUD.

| SUPPLIER | PART NUMBER | CABLE SIZE |
|----------|-------------|-------------------------|
| AMP | 342103 | 0.25-1.6mm ² |
| AMP | 342143 | 1.0-2.6mm ² |

OR ANY OTHER MANUFACTURERS EQUIVALENT TERMINAL.
- FOR OUTLINE & PANEL DRILLING, SEE 2995X10008 (A4).
- CONNECTIONS TO THIS COMMUNICATIONS FACILITY IS BY SCREENED, TWISTED PAIR CABLE, ON SITE. WHEN WIRING OTHER FACILITIES ENSURE THAT THESE TERMINALS ARE NOT OBSCURED BY OTHER WIRE RUNS.
- CONTACTS SHOWN THUS ARE INTERNAL RELAY CASE ASSEMBLY AND CLOSE WHEN THE RELAY CHASSIS IS WITHDRAWN FROM THE CASE.

FOR INFORMATION ONLY
UNCONTROLLED COPY
NOT SUBJECT TO UPDATE

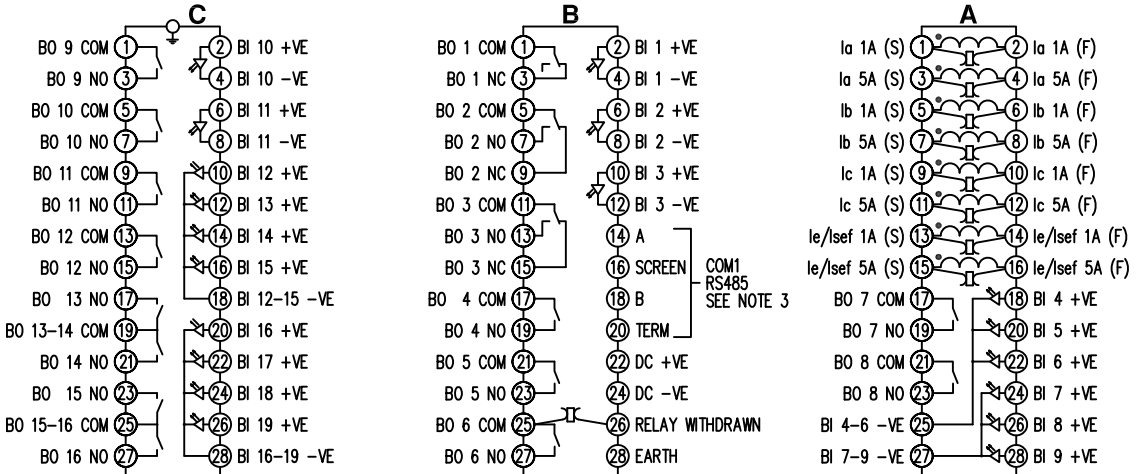

COMMS
BLANKING
PLATE

| | | | | |
|---|-------|----------|------------|-----|
| 2 | RDW | 18/07/07 | MN435/2886 | RDW |
| 1 | | 19/02/07 | CHANGE | |
| | ISSUE | DATE | NOTED | △ |

MATERIAL:

Dimensions in millimetres : Surface texture in micrometres.
Machine where marked ✓
For explanation of dimensions, tolerances, notes etc. see B.S.308.
Limit on untoleranced unmachined dimensions ±
Limits on untoleranced machined dimensions to B.S.4500;
i.e. up to 6±0.1; over 30 to 120±0.3; over 315±0.8;
over 6 to 30±0.2; over 120 to 315±0.5;
General unmachined angular tolerance ±

Finish:
Treatment:

Title:
TERMINAL ID & WIRING DIAGRAM FOR RM PLATFORM
(4I,19BI,2CO,13NO,1NC,RS485) E8 CASE

SIEMENS PROTECTION DEVICES LTD.

Original Scale:
NTS

First used on:
Similar Articles:
Supersedes:
Drg. No.
2435W40003